

G131

ORDERING CODE

420213XXXX

APPLICATION

TIPPER
WATE BOWSER
RECOVERY VEHICLE
LIFTING PLATFORM



TECHNICAL SPECIFICATION

GEAR BOX TYPE	BHARATH BENZ G131
TORQUE	300 NM
ROTATION DIRECTION	ENGINE DIRECTION
ENGAGEMENT TYPE	PNEUMATIC
PTO INTERNAL RATIO	1.32
WEIGHT	12.6kg(with quill shaft)
DURATION OF OPERATION	5MIN (max)
OPTIONS	PUMP 4BOLT - 43,57,65 FLANGE SPICER 1300

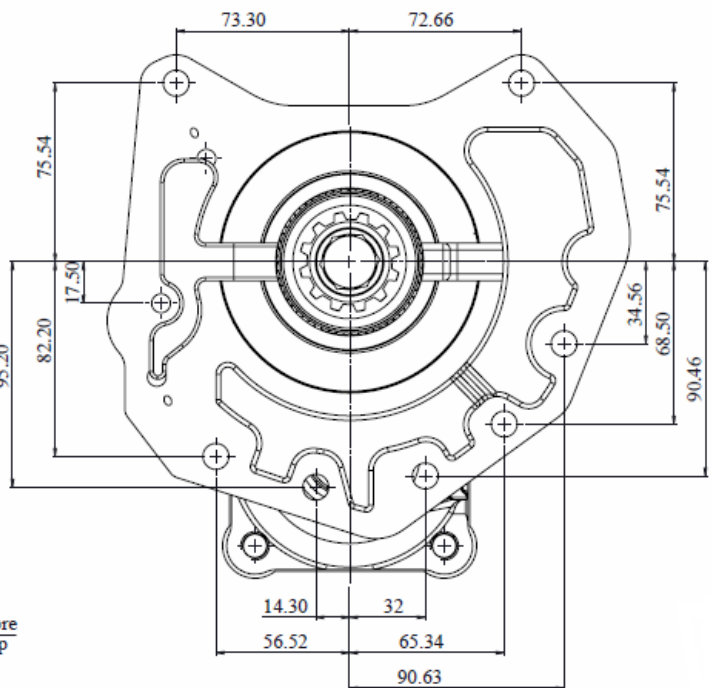
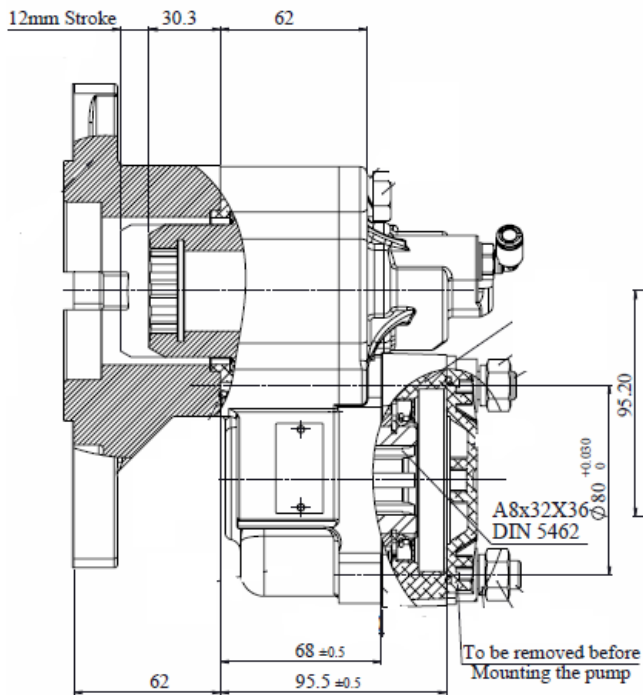

PTO WITH PUMP, PTO WITH FLANGE COMBINATION WILL BE SUPPLIED AS PER CUSTOMER REQUIREMENT

IPH reserves the right to modify the technical data mentioned into this catalogue without notice.
The herewith mentioned data are not bounding.