

GBS 40

ORDERING CODE

IPHTA03XXX

APPLICATION

TIPPER
WATE BOWSER
RECOVERY VEHICLE
LIFTING PLATFORM



TECHNICAL SPECIFICATION

GEAR BOX TYPE	TATA GBS 40
TORQUE	600 NM
ROTATION DIRECTION	COUNTER ENGINE DIRECTION
ENGAGEMENT TYPE	PNEUMATIC
PTO INTERNAL RATIO	1
WEIGHT	7 kg
DURATION OF OPERATION	30MIN (max)
OPTIONS	PUMP 4BOLT - 43,57,65 FLANGE SPICER 1300

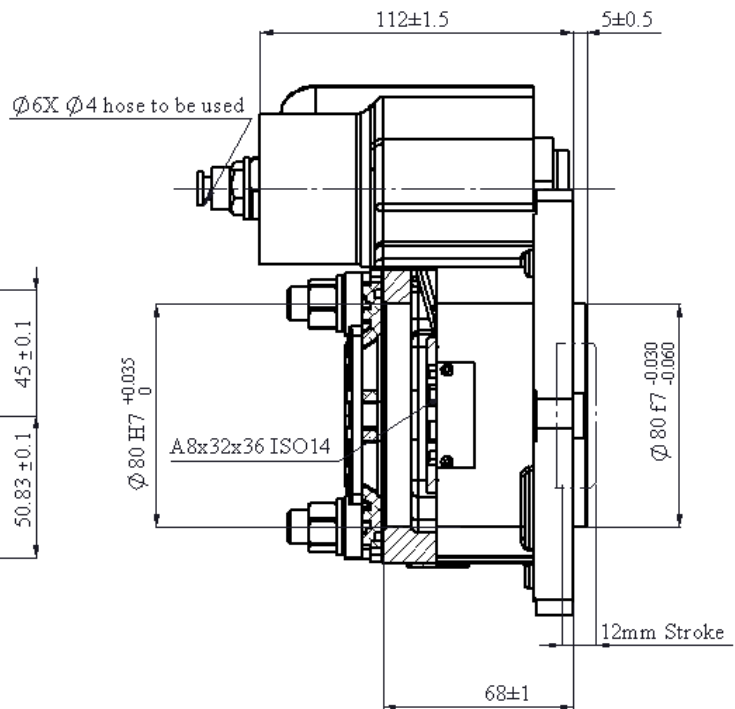
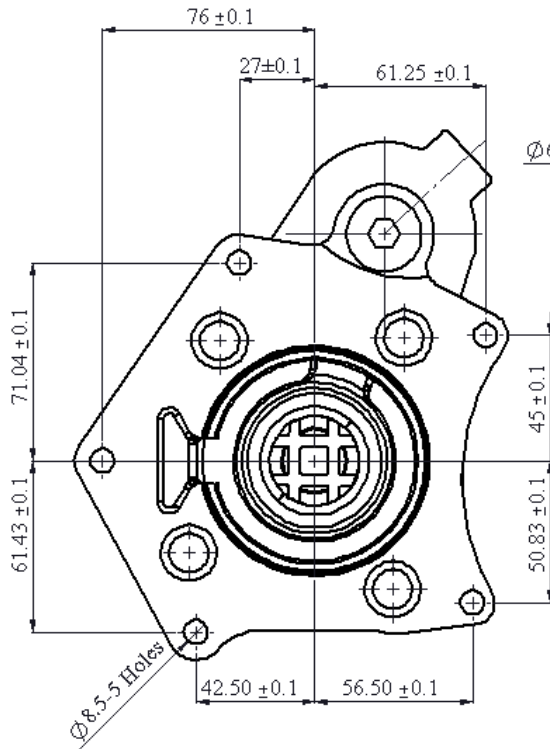

PTO WITH PUMP, PTO WITH FLANGE COMBINATION WILL BE SUPPLIED AS PER CUSTOMER REQUIREMENT

IPH reserves the right to modify the technical data mentioned into this catalogue without notice.
The herewith mentioned data are not bounding.