

TP10

ORDERING CODE

60120783IN



TECHNICAL SPECIFICATION

TECHNICAL		SPECIFICATION	
Flow rate	100 l/min	Fluid temperature	-25°+ 80°C
Max working pressure	220 bar	Viscosity range	12-100 cSt
Max peak pressure	350 bar	ISO 4406	19 / 16 25µm
T port max pressure	20 bar	Weight	3.8 kg
Max pneumatic pressure	10 bar	Mineral oil	ISO VG46

- Pneumatic operated 100/min distributor for tipper vehicles.
- It performs tipping, fast lowering and proportional lowering (by means of proportional pneumatic control).
- The inlet check valve and the adjustable relief valve are built-in.
- The relief valve range is from 130-220 bar.
- End-of-stroke rope.

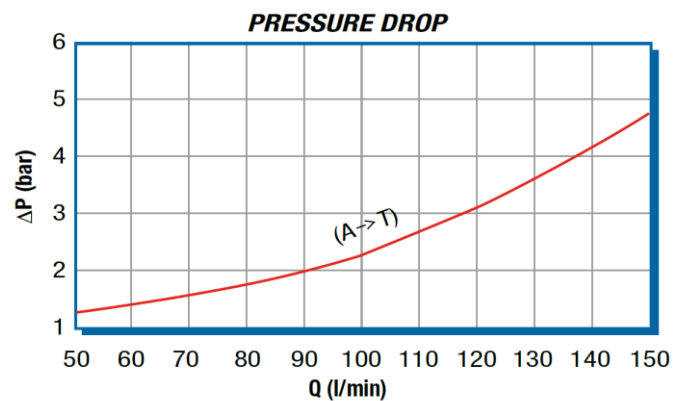
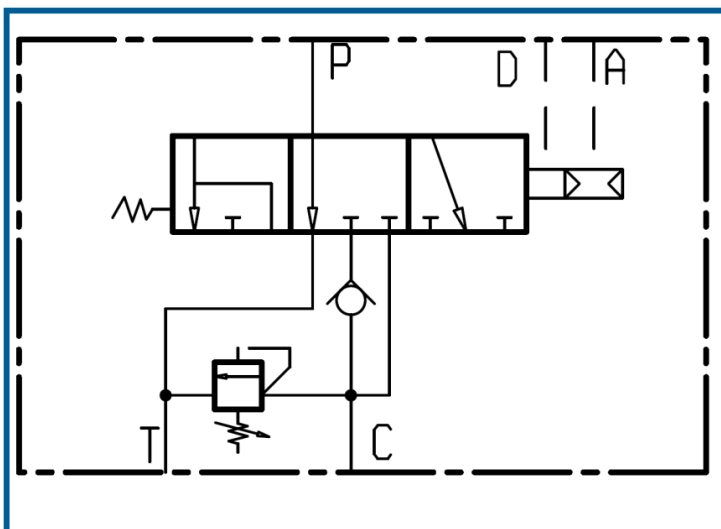

THE ABOVE SPECIFICATIONS REFER TO OIL TYPE ISO VG 46 AT 50° C ($\nu = 30$ cSt)

DC VALVE (STANDARD VERSION)

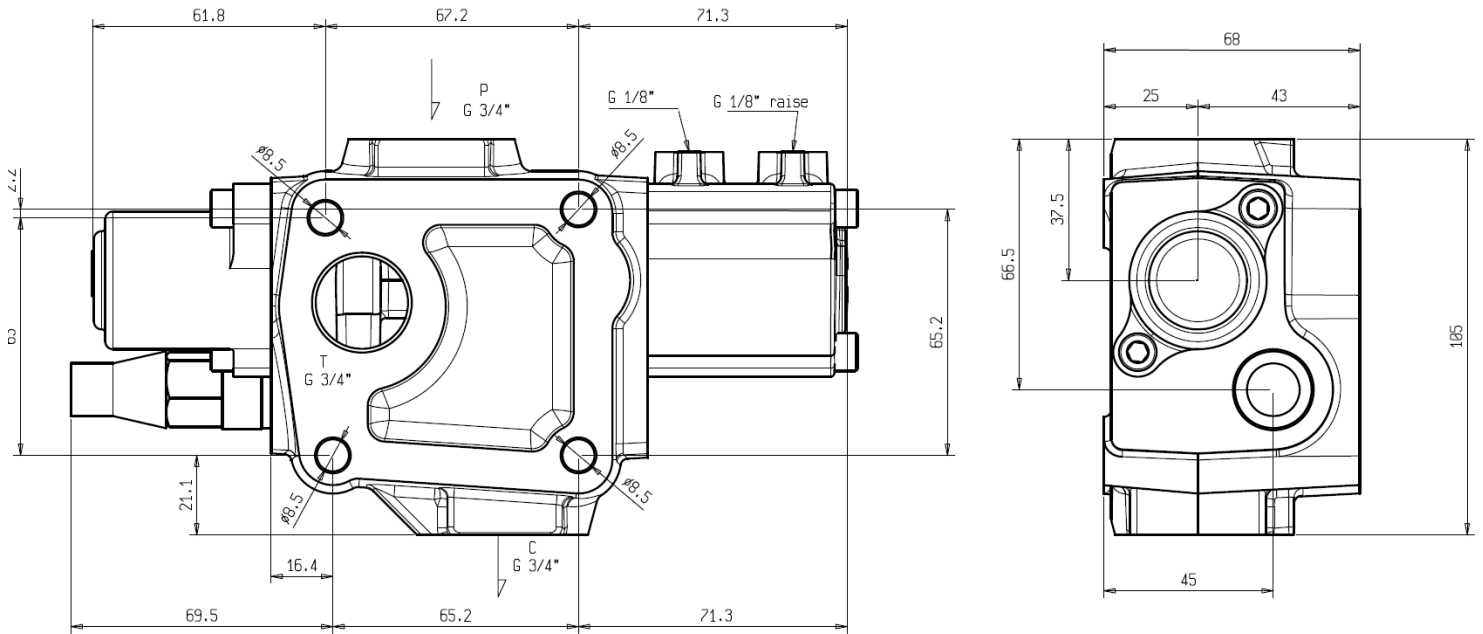

EXAMPLE OF MOUNTING

