

ZF 9S 1110

ORDERING CODE

420241XXXXX

APPLICATION

TIPPER
 WATE BOWSER
 RECOVERY VEHICLE
 LIFTING PLATFORM

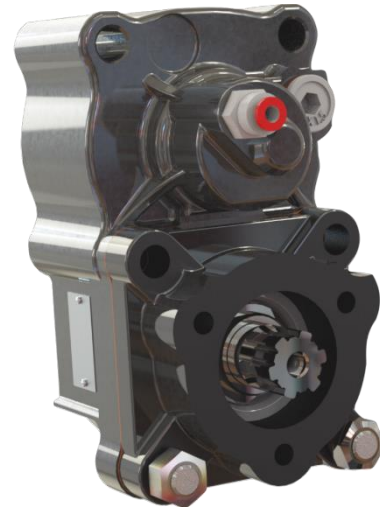

TECHNICAL SPECIFICATION

GEAR BOX TYPE	ZF 9S 1110
TORQUE	300 NM
ROTATION DIRECTION	ENGINE DIRECTION
ENGAGEMENT TYPE	PNEUMATIC
PTO INTERNAL RATIO	1.32
WEIGHT	13.5 kg(with quill shaft)
DURATION OF OPERATION	5MIN (max)
OPTIONS	PUMP 4BOLT - 43,57,65 FLANGE SPICER 1300

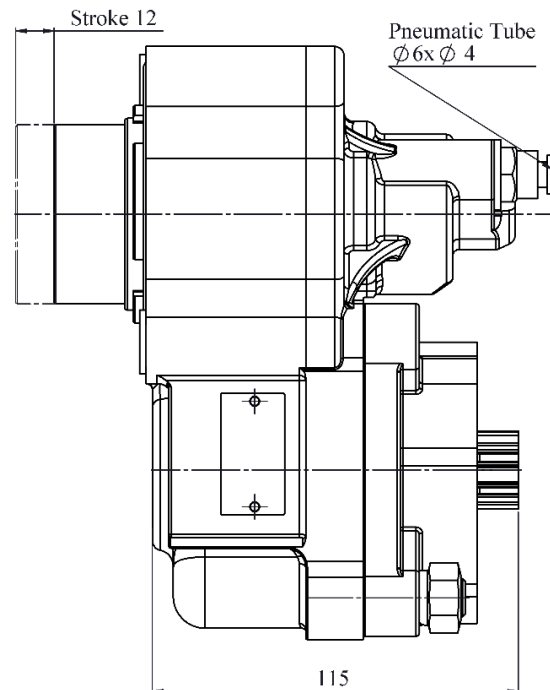
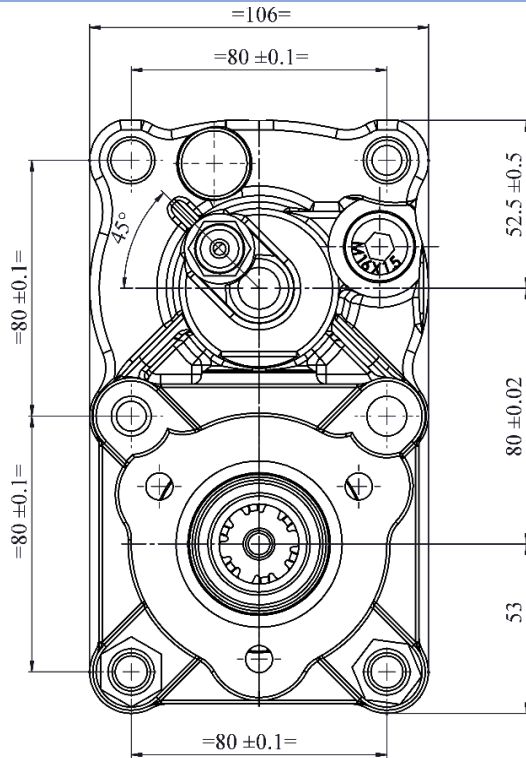

PTO WITH PUMP, PTO WITH FLANGE COMBINATION WILL BE SUPPLIED AS PER CUSTOMER REQUIREMENT

IPH reserves the right to modify the technical data mentioned into this catalogue without notice.
 The herewith mentioned data are not bounding.